



---

**ZAP!**

**Zoo Activity Packet**

---

## **Bringing Up Baby**

A Teacher's Resource  
for Kindergarten

# Bringing Up Baby

# ZAP!

## Zoo Activity Packet

---

### Table of Contents

Learning Objectives	page 3
Background Information for the Teacher	page 4
Pre-Visit Activities	page 9
At-the-Zoo Activities	page 15
Post-Visit Activities	page 20
Resources	page 36
Evaluation Form	page 40

## Learning Objectives

The work sheets and activities in this Zoo Activity Packet are suggested to help students to learn that:

1. Animal babies come in many different sizes. Some look like their parents when born and some have completely different physical characteristics than their parents.
2. A baby animals growth rate is dependent upon its environment and its chances for survival in this environment.
3. The amount of care given by adults to their babies varies greatly among the species.
4. Zoos play an important role in helping to protect wildlife by doing research on animals and survival of their young.

## Bringing Up Baby

### Background Information for the Teacher

One of the requirements of all living things is that they be able to reproduce. Usually, nature does the best it can to ensure the baby animal's chances to survive.

#### Survival Skills

Animals live in habitats to which they are suited and so in turn, do their babies. If the animal lives in a warm climate, it often is born naked, but if the animal lives in a cool climate, they are usually born with fur. Llamas have long, shaggy hair when born, for warmth, because they live in cool, mountain climates. Animals in the mountains must also be good climbers. They are born with a sense of balance and can usually climb about 30 minutes after birth. In forest or jungle areas, many baby animals live up in trees, where fewer animals can catch them. Most of the monkeys at our zoo would be good examples of this.

#### Growth Rate

An animal's growth rate is also affected by its habitat and its living situation. Animals born in unprotected places or whose parents cannot protect them from predators must be born more fully developed. In general, plant-eating mammals are better developed at birth than predators. For example, zebras are able to run within an hour of their birth, because they must keep up with the moving herd. Rabbits also are grown and independent in a few weeks because the mother may have as many as three families in one summer. Most types of cats, however, remain hidden in a den for weeks after their birth. Their eyes are closed for a week or more. Usually, carnivores have much to learn about hunting and develop their skills over a longer period of time. Even in the same class of animals, the capabilities of newborns vary. Many birds are born without feathers and are unable to leave the nest. The macaws are a good example of this type of bird at our zoo. Ducks, however, can walk, swim, and eat solid food as soon as they are dried off after hatching.

#### How Big is Baby?

Animals' sizes at birth also vary greatly. The marsupial family probably has the smallest babies compared to the size they will be as adults. The baby opossum (a marsupial) will be 1/4 inch long at birth, compared to the kitten's 6-7 inches. Both animals will end up approximately the same size as adults. A kangaroo (another marsupial) is only 1/3 inch long when born but will grow to be about 6 feet tall and 9 feet long. Compare this to larger animals, such as the giraffe, which, at birth is already as tall as a human (6 feet tall).

The animal's size sometimes determines how the baby animal will react when danger threatens. Smaller babies usually stand still or rely on camouflage to conceal them. A larger baby's size, however, makes it impossible to hide, so they usually run or seek protection from adult animals in a herd.

The looks of a baby animal compared to its parents also vary a great deal. Most reptiles resemble a smaller version of their parents at birth. Insects and amphibians go through stages from birth to adulthood in a process called metamorphosis. The baby's appearance changes drastically in each of these stages. Insect stages include egg, larva (e.g., caterpillar), pupa (e.g. inside a cocoon), and adult (e.g., moth). Amphibian stages vary considerably and not all go through the same number and kind of changes. In general, amphibians begin as an egg, go through a larval stage (e.g., frog or toad tadpole or a newt eft) and then become adults.

## **Taking Care of Baby**

The vast majority of animal species do not care for their young. As a general rule, if an animal is guided wholly by instinct as an adult, it will get very little help from its parents as a baby. But if it must learn many things to be a successful adult, it spends more time with its parents to learn these skills.

Closely related to the amount of care provided is the number of young produced in a single birth. Most fish, insect, and reptile babies receive little help. The parents often lay eggs and leave before they hatch. Many of these unprotected babies do not survive, of course, so these species usually lay a larger number of eggs to ensure survival of the species.

Many more bird and mammal babies are helpless at birth. The parental role is one of food gathering, protection, and teaching. The responsibility for this sometimes rests with only one parent, or both, or a social group of adults and older siblings. The male's role is often limited in caring for the young. In some species, such as zebras and lions, the male guards the territory. Other fathers, such as wolves, not only help defend, but also bring food for the cubs and the mother. In some species, like emus and emperor penguins, the father is the main caretaker.

Initially, the parents' main job is that of finding food and protection. These don't always both occur, however. The pelican feeds its babies, but may not protect them if danger threatens. When only one parent is the caretaker, the babies must hide and stay very quiet while the parent is off searching for food. A baby bat normally clings to its mother with its teeth and thumbs. The mother then hangs it upside down when she leaves to hunt. Other animals, like monkeys, carry their young to good food gathering areas, where they learn to find their own food.

## **Lessons in Survival**

As the animal matures, the parent teaches it to hunt for its own food. Bears spend many hours teaching their cubs to catch fish. Cheetah mothers demonstrate how to stalk their prey. Many young animals' play behavior helps them to learn these food gathering techniques. When lion cubs chase each other and spring on each others' tails, they are practicing stalking and pouncing behavior. Beavers must learn to be good swimmers and the mother holds the kit's tail to steer it in the right direction as it learns.

The more complicated the animal's behavior, the more it must learn. Monkeys must learn how to behave in the social group and so spend more time in their parent's care. Apes take the longest of all mammals to mature. It takes 5 years for a pygmy chimp to become fully independent.

Adult animals who care for their young must also expend a lot of energy in protection. Crocodile mothers will pick their babies up in their mouth and carry them to safety. When an elephant is born, the mother uses her feet and trunk to help lift the baby into a standing position. The baby often walks between its mother's front legs for protection.

Those adults who cannot protect their young by fighting will often try to attract attention to themselves. It is interesting to note that a killdeer uses the broken wing ploy only in the presence of predators. If a cow or horse approaches, they will fly into the face of the intruder until it leaves.

In the wild, those adult animals that provide protection will defend their young fiercely. It is impor-

tant that humans respect this fact and learn to keep their distance.

### **Zoo Babies**

As the number of animal species continues to decrease, zoos are trying to prevent this by continued research on animals and their babies. They're researching ways to increase the number of babies born, as well as what animals must have to live. For example, some zoos with baby chimps have playrooms for them so they can research more about ape behavior. Scientists are learning more all the time about the social bonds between monkey species. Where you used to see just a male and female pair at the zoo used for mating, now you more often see an exhibit with an entire troop. In this way the babies learn these behaviors naturally.

In zoos, animal babies get medical care and protection from predators. If a baby is rejected by the mother, many animals can be hand-raised to improve their chances of survival.

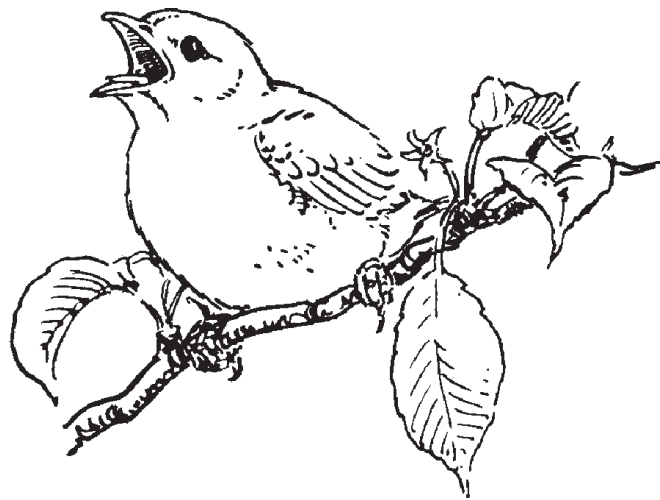

## VOCABULARY

Students can be expected to understand and properly use the vocabulary words listed below:

- Adult:** fully grown and mature
- Den:** the home of an animal
- Litter:** the offspring of one animal at one birth
- Nurse:** to drink milk from the mother's milk gland
- Pouch:** part of an animal's body (usually a marsupial) that is like a pocket
- Protect:** keep safe; guard
- Raise:** to bring up and take care of
- Scent:** the odor left by an animal on a surface passed over
- Young:** a recently born or hatched animal



## Young Animal Names

bear -- cub	
bobcat -- kitten	
bird -- fledgling, nestling	
cheetah -- cub	
chicken -- chick	
cow -- calf	
deer -- fawn	
dingo -- pup	
duck -- duckling	
fish -- fry, fingerling	
fox -- cub, kit	
gazelle -- fawn	
gibbon -- baby	
giraffe -- calf	
goat -- kid	
goose -- gosling	
guinea pig -- piglet	
horse -- colt, foal	
	kangaroo; wallaby -- joey
	leopard -- cub
	lion -- cub
	monkey -- baby
	otter -- pup
	pig -- piglet
	prairie dog -- pup
	rabbit -- kit
	sea lion -- pup
	sheep -- lamb
	swan -- cygnet
	tiger -- cub
	turkey -- poult
	turtle -- hatchling
	zebra -- foal, colt

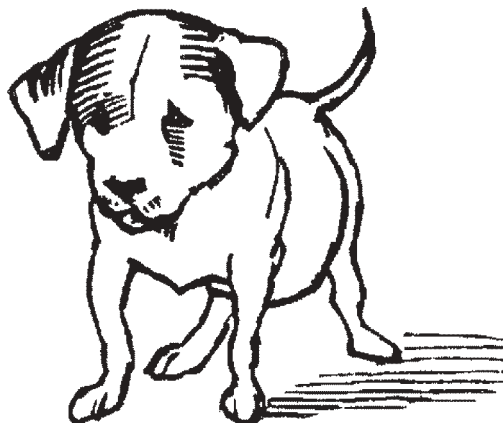

## Using Smell to Find Your Family

### *A Pre-Visit Activity*

#### **Background**

Explain to the children that in nature, each parent recognizes its own baby by the baby's individual scent. For example, all baby seals smell like seals, but a specific mother seal can recognize her baby by its own special scent.

#### **Activity**

Gather a variety of strongly scented, non-toxic liquids such as vanilla, peppermint extract, almond extract, lemon juice, vinegar, etc.

Before the activity, prepare two identical sets of scent containers (Film canisters work well, and many photo shops will give you as many as you need.) Make enough so that each child will have one container or one lid.

Wet two sets of cotton balls with each liquid. Label the matching lids and containers with an obscure code for your information. To transfer the scent on the cotton ball to the lid, shake each container with the lid on just before using it. Give each student a scented container or lid.

Each "baby" (student with lid) should try to locate his/her "parent" (student with container) in the room by matching the scents.



## **Animal Authorities**

### *A Pre-Visit Activity*

Have each child or pair of children select an animal to study to become an “animal authority.” Attempt to keep the selections within the animal population of our Fort Wayne Children’s Zoo and, if possible, within the area of the zoo to be explored on your field trip (for example, the African Veldt, Australian Adventure, Indonesian Rain Forest, or Central Zoo).

Children may go to the library to check out books about their selected animals that can be read at home with the help of a parent or older child, or with an older "buddy" at school.

Encourage children to learn as much as possible about their animal and to answer the following:

What does it look like?

What size is it?

What foods does it eat?

What kind of home does it make?

How many babies does it have?

How does it care for its babies?

Each child could draw a picture of his/her animal and a class “Animal Book” could be made. A three-dimensional model could be made from clay and displayed in a class “zoo.”

Or, use the work sheet on the following page to help children record information they learn about their animal.

# I'm an Animal Authority

My animal has:

- teeth
- no teeth
- a beak

My animal lives:

- on land
- in water
- both

My animal is:

- big
- medium
- small

My animal has:

- legs
- no legs

My animal has:

- fur
- feathers
- scales

My animal has:

- paws
- claws
- hooves
- fins
- flippers
- webbed feet

My animal's babies:

- hatch from eggs
- are born alive

My animal has: \_\_\_\_\_ babies

Here's a picture of my animal

Teacher: Have students circle the answer that applies to their animal. Have students draw their animal or paste a picture in the circle.

## Baby Animal Web Mobile

### *A Pre-Visit Activity*

Ask the students what things baby animals need (for example: food, water, shelter, and protection). Encourage them to think about what they needed when they were babies, and what they still need.

Then ask them how baby animals get the things they need in their environment.

Extension: Allow the children to cut pictures from magazines, or draw pictures, that show baby animals being cared for in the ways discussed.

Create a web or mobile using the pictures and words provided by the class.

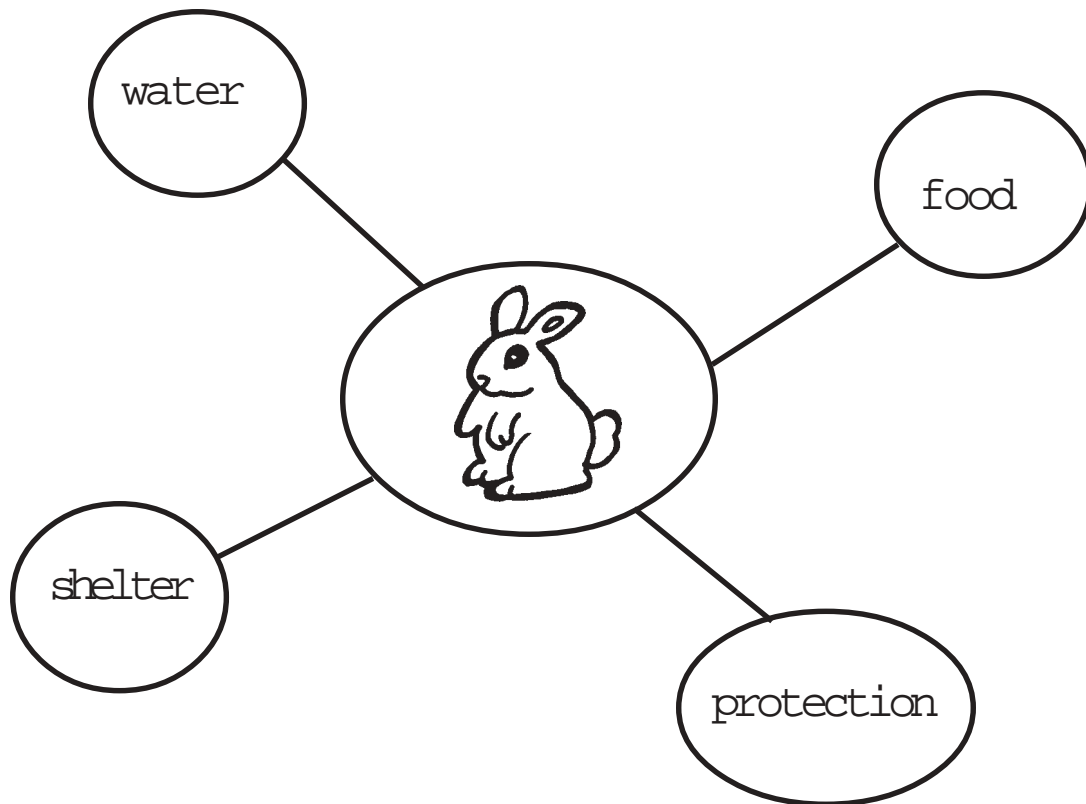

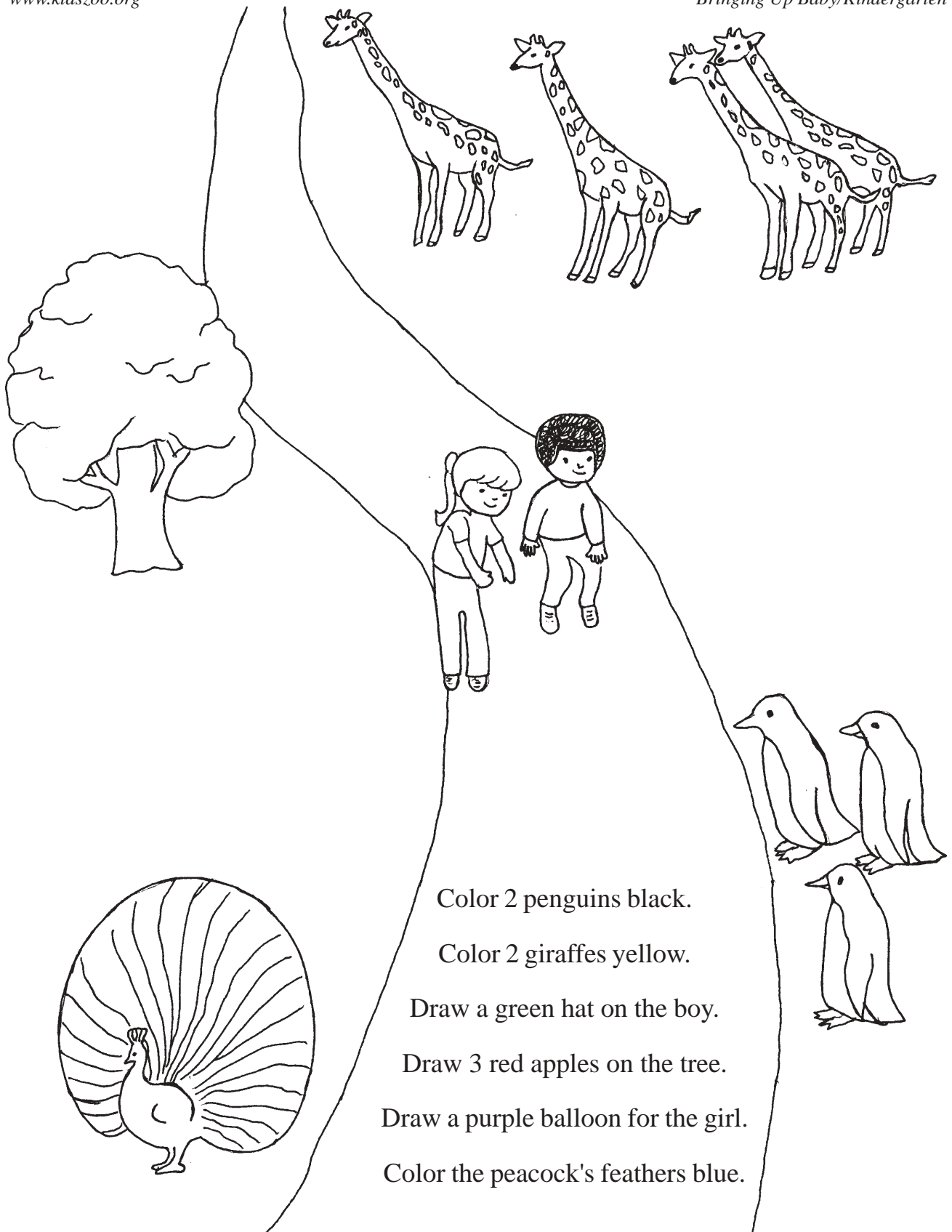

Color 2 penguins black.

Color 2 giraffes yellow.

Draw a green hat on the boy.

Draw 3 red apples on the tree.

Draw a purple balloon for the girl.

Color the peacock's feathers blue.

Teacher: Use this activity sheet to help students learn to follow directions.

## Other Pre-Visit Activities

### **The Animals at the Zoo Song**

Ask students to brainstorm a list of animals they will see at the zoo.

Use their ideas to create your own song "The Animals at the Zoo," sung to the tune of "The Wheels on the Bus."

### **Talk to the Animals**

Get the song "Talk to the Animals." Play the recording and discuss with the children how the animals talk to each other.

Have a tea party with animal cookies.

Ask the children to sort the animal cookies into groups.

Have the children imagine what the animals might be saying to each other, and how they might communicate with each other. What kinds of stories could the animals tell each other about their babies?

### **Animal Baby Names**

Some animal species have special names given to their babies. You will find a list of these on page 11 of this packet. These can be fun to use in discussions, "word of the day" activities, or in stories.

After the baby animal names have become familiar to the children, use them as vocabulary or in a bingo game. Use animal cookies as the bingo markers.

## At-the-Zoo Activities

### Observe Communication Behavior:

- Are the animals “talking” to each other?
- Is a baby “sniffing” to find its mother?
- Is a mother “sniffing” to find her baby?
- Are a mother and father animal “talking” to each other?

### Observe Zoo Babies

- As you walk around the zoo, look for baby animals.
- Are the baby animals taking care of themselves, or are they still receiving care?
- Are the baby animals being cared for by their parents or a zoo keeper?
- How are the baby animals’ needs being met?



### Scavenger Hunt

- Give each child or group of children a copy of the scavenger hunt on page 18.
- Let them see how many animals they can find for each clue.
- Encourage them to think about different types of animals that might share the trait. For example, “Are birds the only animals that hatch from eggs?”
- Children can copy animal names off of zoo signs.

## More At-the-Zoo Activities

### Animal Parenting Skills

Give each child or group of children a copy of the Animal Parenting Skills sheet.

Ask the children to look for examples of animal parents caring for their babies in ways similar to how human parents care for their children.

### Animal Authorities

If each child or pair of children selected an animal to study prior to the zoo visit, make sure to help them find the animal at the zoo.

Ask them to observe the animal using their eyes, ears, and nose.

Ask them to imagine what the animal would feel like if they could touch it.

How is their animal being cared for at the zoo? Is it being cared for by a parent or a zoo keeper?

### Find the Mystery Animal

Read the book Is Your Mama a Llama by Deborah Guarino before the zoo visit.

Talk about the clues that each animal baby gave about its mother.

Give the students clues to a “Mystery Animal” that can be found at the zoo.

Encourage the children to look for this animal while at the zoo.

# ANIMAL PARENTING SKILLS

As you walk around the zoo, find examples of animals parents acting in the ways shown below. Write the animal's name on the blank.

feeding

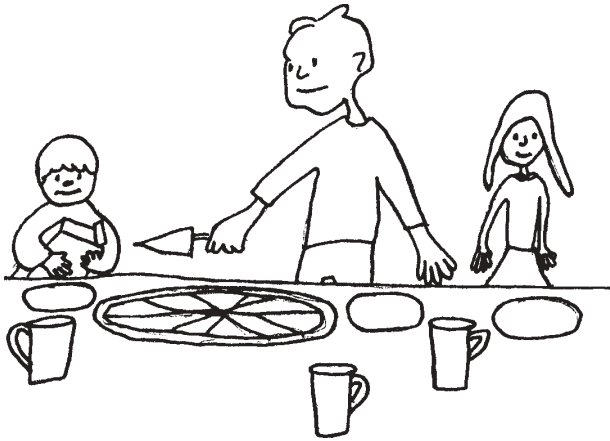

\_\_\_\_\_

cleaning

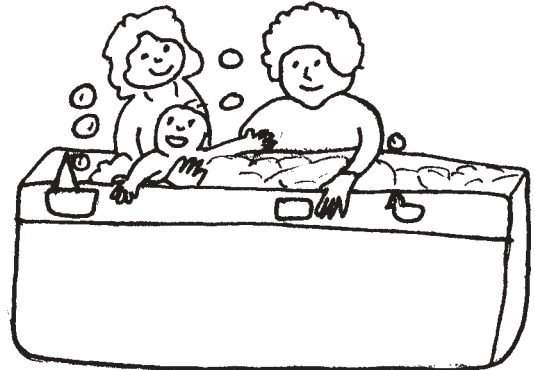

\_\_\_\_\_

carrying



\_\_\_\_\_

leading

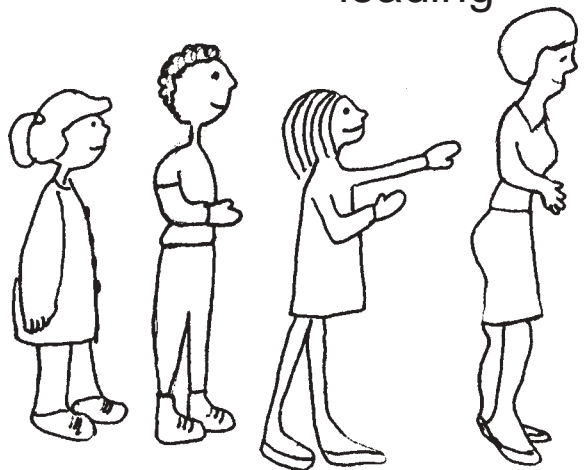

\_\_\_\_\_

# Zoo Scavenger Hunt

1. Find an animal whose baby hatches from an egg.

---

2. Find an animal whose baby rides in a pocket.

---

3. Find an animal whose baby is called a pup.

---

4. Find an animal whose baby can swim.

---

5. Find an animal whose baby has sharp teeth.

---

6. Find an animal whose baby has feathers.

---

# MYSTERY ANIMAL



Clue #1: I live in Africa.

Clue #2: I eat leaves from tree branches.

Clue #3: I have brown spots and a long neck.

Clue #4: I am the tallest animal in the world.

Who am I? \_\_\_\_\_

*Teacher: Use the clues to help students discover the identity of the mystery animal during your trip to the zoo.*

# MYSTERY ANIMAL



Clue #1: I hatched from an egg.

Clue #2: I carry my home on my back.

Clue #3: I live on land, not on the water.

Clue #4: A rabbit can't beat me in a race.

Who am I? \_\_\_\_\_

*Teacher: Use the clues to help students discover the identity of the mystery animal during your trip to the zoo.*

Answers (remove or cover before reproducing):      GIRAFFE      TORTOISE

## Post-Visit Activities

### Animal Authorities

Encourage the children to share the information they found at the zoo about their chosen animal. Include what they learned with their senses.

Each child could draw a picture of his/her animal and a class "Animal Book" could be made. A three-dimensional model could be made from clay and displayed in a class "zoo."

### Animal Alphabet

Read the book Animal Alphabet by Bert Kitchen.

Ask the children if they saw any of the animals from the book at the zoo.

Ask the children what zoo animals they saw that begin with each letter of the alphabet.

Compose a partial alphabet of animals the class saw at the zoo.

### "SKUNK!" card game

Prepare the zoo activity cards on page 25 so there is a matching card for each animal.

Cut out the skunk card at right.

Deal each person cards until they have all been dealt.

The game proceeds as in "Old Maid."

The person who ends the game with the skunk card is the "SKUNK!"

Ask the children if they can name the animals in their card matches.



### Are You Me?

Students match pictures of aquatic life at different stages in their life cycle.

Use the picture cards and instructions provided on page 26.

### Pop-Up Book

Using the instructions provided on page 22, have the children make a pop-up book with scenes from their zoo visit.

## More Post-Visit Activities

### **Favorite Animal Graphing**

Ask each student what his/her favorite animal was at the zoo. List the animal names on the board.

Ask the students to stand together with other students who chose the same favorite animal.

When each child is in a group, ask the groups to stand in a straight line next to each other.

Let the children tell which “favorite animal” had the most people choose it based on the body graph they have just made.

Graph the results on the board or on a chart, allowing the students to color in their spot on the graph.

**Extension:** Create a graph using the answers gathered by students for the Zoo Scavenger Hunt. Example: For question 1 (Find an animal whose baby hatched from an egg), graph the number of students who answered duck, peacock, chicken, fish, snake, etc.

### **Sequencing Activity: Changing and Growing**

Discuss how some animals look like smaller versions of their parents when they are born or hatched. Point out that other animal babies look completely different from their parents until they have undergone a metamorphosis. Tell the children that one example of the first is a chicken; an example of the second is a frog.

Give each student a copy of the chicken life-cycle on page 23. Let them color the pictures and cut them out.

Ask the children to put the pictures in the correct sequence, and discuss as a class the different pictures.

Repeat the steps for the frog life-cycle on page 24, pointing out the different stages in the metamorphosis.

Let the children chose one set of life-cycle cards to make into a bracelet.

For each child, cut a piece of tagboard long enough and wide enough to hold all four cards.

Let the children glue their chosen life-cycle in the correct sequence onto the tagboard.

Glue or staple the ends of the tagboard together to make a bracelet.

### **Animal Puppets**

Have each child choose their favorite animal that they saw at the zoo. Each child can then make a puppet using a sock, tagboard, paper bag, etc.

The class can work together, or in small groups, to present a puppet show.

Encourage the children to have their animals discuss the animals’ babies, homes, likes and dislikes, and other behaviors observed at the zoo.

## How to Make a Pop-Up Book

1. Fold 12" x 18" paper in half to make a 9" x 12" page.
2. On the fold, measure a 4 1/2" long and 2 1/2" deep rectangle.
3. From the fold, cut the paper rectangle, folding back the flap.
4. Crease the flap and pull out the pop-up.
5. Fold down and crease the pop-up.
6. Glue animal pictures on the front of the pop-up.
7. Measure, mark, and cut out the pop-ups in different places on the folds of the other pages.
8. Glue the pages together like an accordion (the bottom page of one page to the top of another) to make a book.

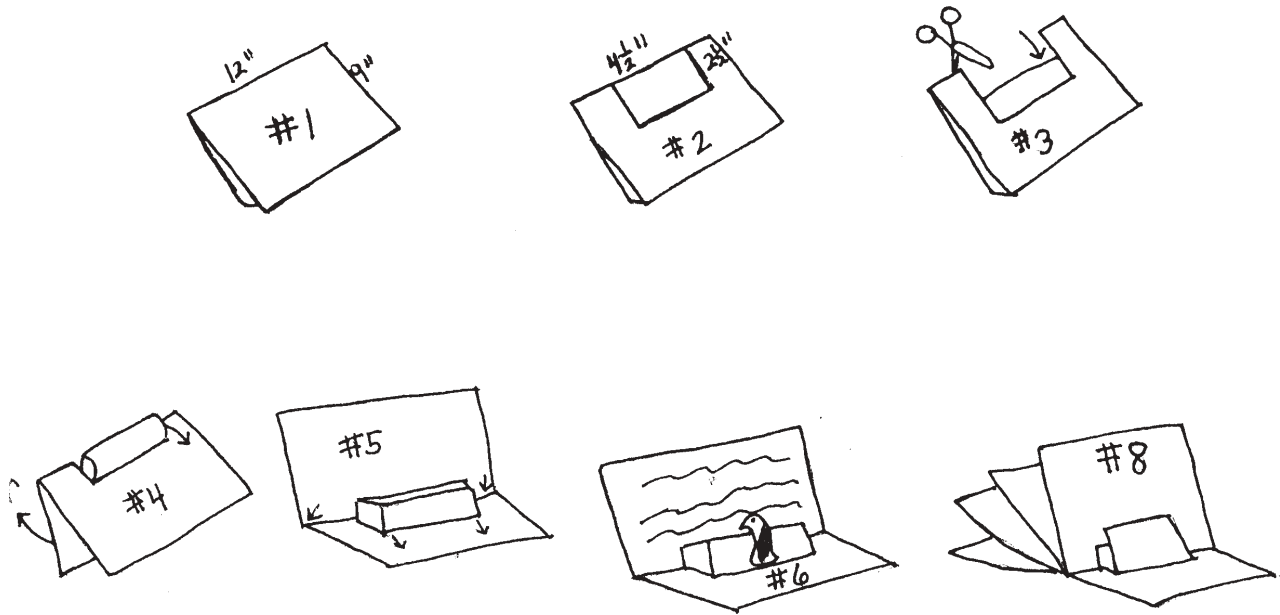

(Adapted from "Come With Me" science series, S/S Publishing Co., 3550 Durock Road, Shingle Springs, CA 95682).

# Changing and Growing

Cut out each picture. What happened first, second, third and last? Place the pictures in order, then glue them on a sheet of paper.

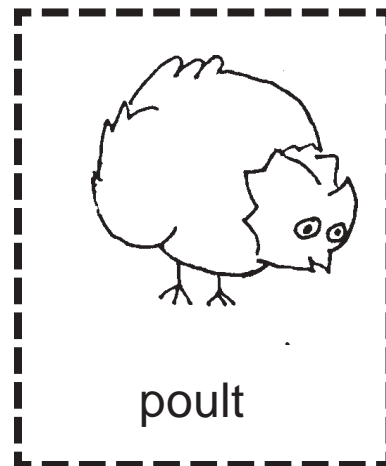
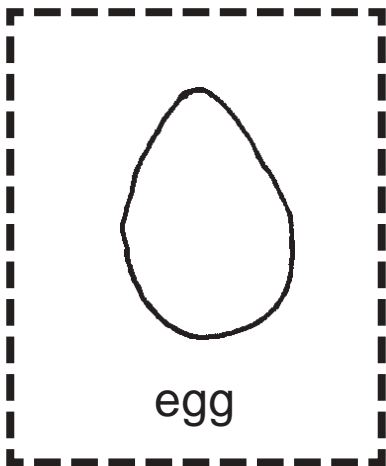
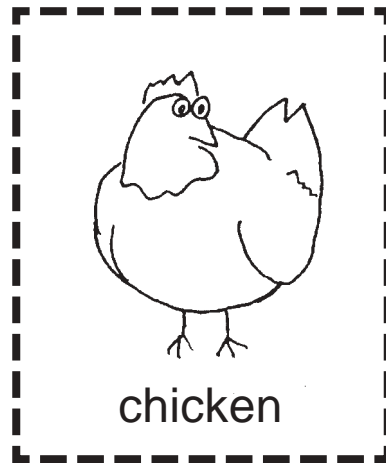
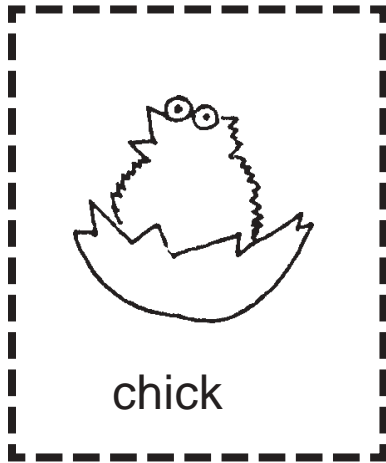

# Changing and Growing

Cut out each picture. What happened first, second, third and last? Place the pictures in order, then glue them on a sheet of paper.

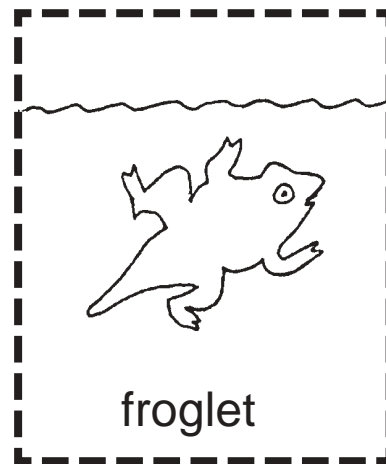
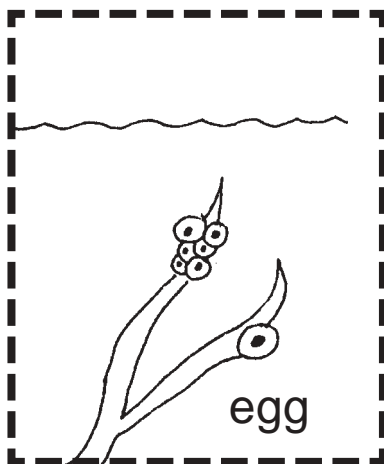
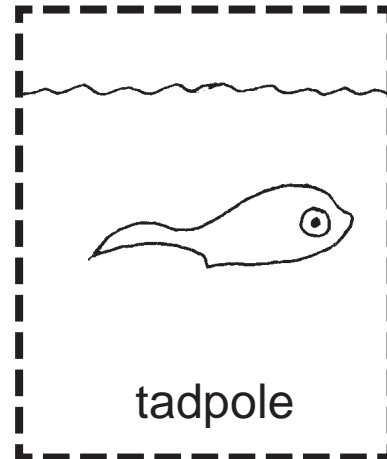
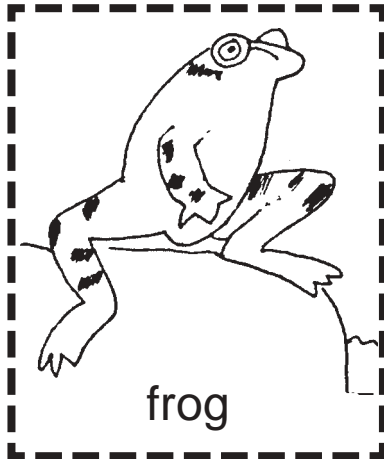

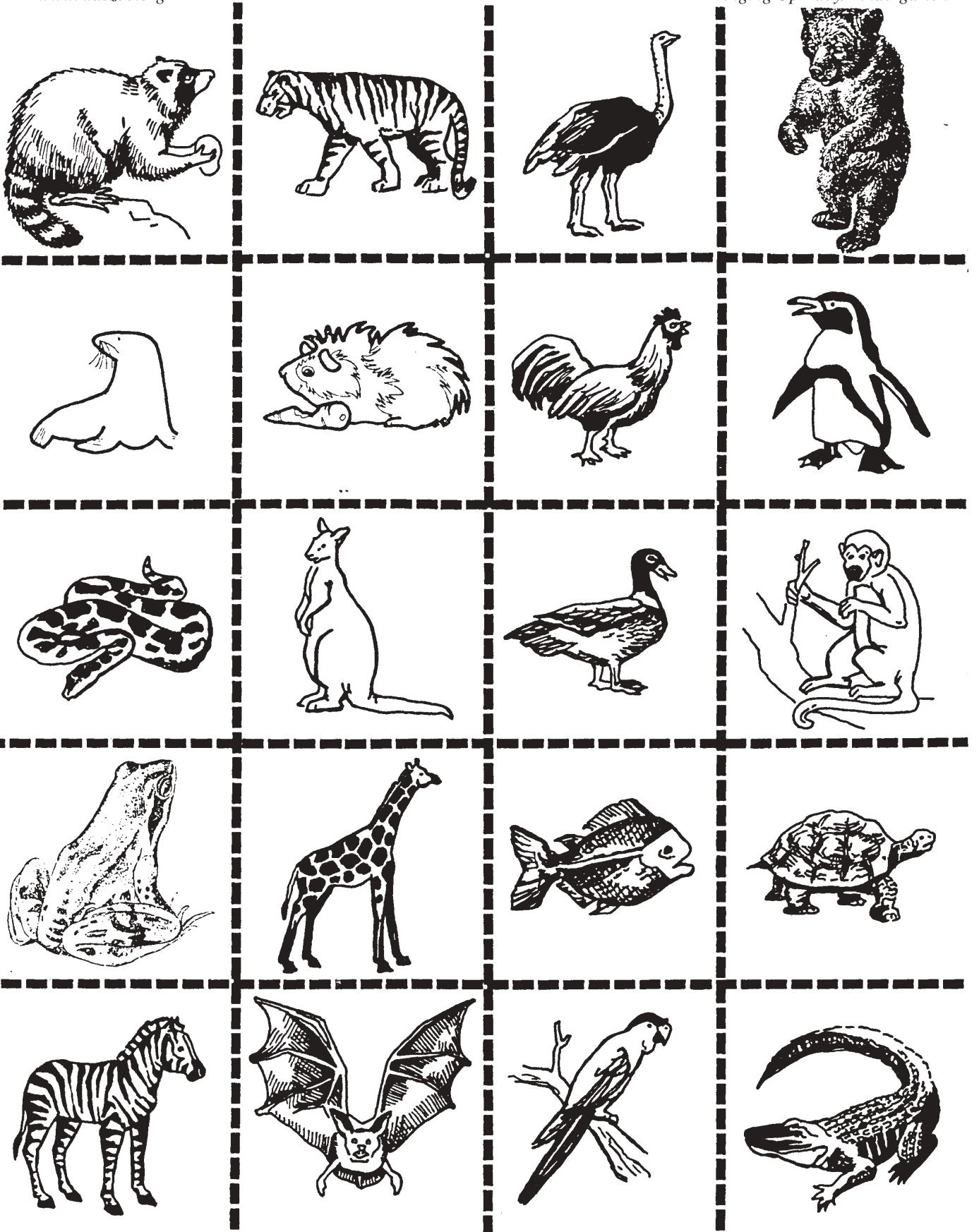

Teacher: Copy and cut out these cards to play the "SKUNK!" card game.

# Are You Me?

## Objective

Students will be able to recognize various young stages of aquatic animals and match them with corresponding adult stages.

## Method

Using picture cards, students match pairs of juvenile and adult aquatic animals.

## Background

Many animals look significantly different in their earliest stages of development, compared to adulthood. This is obviously true for some aquatic insects. Many aquatic insects undergo metamorphosis. Metamorphosis means change during growth. Some insects experience simple metamorphosis while others undergo complete metamorphosis. In simple metamorphosis, the insect egg hatches to produce a **nymph**. Insect nymphs have essentially all the features of adults. As they grow, they are visibly similar at each stage.

Insects that experience complete metamorphosis are characterized by eggs that hatch into **larvae**. The larva grows through several stages and then changes into a **pupa**. Pupae are usually encased in a protective cover for their next stage of growth. From the pupae emerge the softbodied, often pale-colored insects. They differ remarkably in appearance from their earlier forms, but are not yet completely formed. Gradually the soft pale body develops firmness and color. In complete metamorphosis, there is little resemblance between the adult and earlier forms.

There are also remarkable similarities and differences between other aquatic animals in different life stages. The eggs of many animals hide their eventual form (alligators, turtles, birds). Pelican hatchlings, for example, may be the closest image of miniature dinosaurs to be found on the planet. Aquatic mammals often are easy to recognize. They frequently do not change as dramatically as some other animals in overall appearance as they grow from young to adult stages.

The major purpose of this activity is for students to recognize that there are differences in the life stages of aquatic animals as they grow. The students will increase their appreciation of the diversity of wildlife as well as their understanding of growth and change in animals.

**Age:** Grades K-2

**Subjects-:** Science

**Skills:** analysis, classification, communication, comparing similarities and differences, matching, recognition, small group work

**Duration:** one or two 20-minute periods: prep time for students to bring family pictures to class

**Group Size:** small groups of three or four students each; card masters are provided; duplicates may be used if needed, or fewer cards if the class is smaller

**Setting:** indoors

**Conceptual Framework Reference:** I.B., I.B.1., I.B.3., I.B.4., III.C.

**Key Vocabulary:** aquatic animals, grow, change, adult, young

**Materials:** cardboard for making picture cards; marking pens or crayons

### Procedure

1. Make pairs of aquatic animal cards. The animals in the pair should be the same kind. For example, one might be a pair of beavers; another might be a pair of pelicans. One animal in the pair should be an adult, the other should be at a younger stage of development. The pairs might include adult, larval, nymph, hatchling, juvenile, infant and/or egg forms of aquatic animals. You may use the masters provided.
  2. Ask the children to bring two pictures from home. One should be of an adult, the other should be a picture of a child. The pictures should be pictures of the same person as an adult and as a child. For example, the pair may be of the student's parent as an adult and in a childhood picture, or it may be a school picture of the student and a picture of the student as an infant.
  3. Divide the class into small groups of three or four students each. Have them hold their own set of paired pictures in their hands. Assign each group a single table or station. Ask them to stand in a circle around that station.
  4. Have the students at each station place their pairs of pictures on the table and mix them randomly. Once the adult-child pictures are mixed at each table, have the entire group shift to another table, so there will not be anyone at the tables where their own pictures are placed.
  5. At the new table, have the group attempt to match pairs of adult/child or student and infant photos.
  6. When the students at each table have completed their efforts to match the pairs, ask all of the groups to return to their original tables, the place they left their own pairs of pictures. Are the matches correct? Ask the students to change any pairs that are not correctly matched. Talk about how difficult or easy it was to correctly match pairs. Introduce the idea that many animals look remarkably different as adults than they appeared in younger forms. Tell the students that they are about to learn how to match young and adult forms of many different kinds of aquatic animals.
  7. Introduce the aquatic animal cards and divide the class in two. Designate one half of the students "adults" and the other half "young animals." Give each student in the "adult group" an "adult" animal image. Give each student in the "young animal" group a "young animal" image. Make sure there is a corresponding match, adult or juvenile, for each card given. Instruct the students to look for their "match" -- pairing the appropriate adult and juvenile forms. NOTE: You can attach each animal card to a string loop so the pictures can be hung around the students' necks as they try to match the pictures.
  8. When all the students have made their choices and think they have a match, let everyone help to see if the matches are correct. Some are more difficult than others and may be confusing. You may show the students the matched images on the master.
  9. Have all of the students look at all of the correctly matched pairs. Look at similarities and differences in how different kinds of aquatic animals grow and change.
- NOTE: This activity can be repeated several times by shuffling the adult and young images and passing them to new "animals" so that each student becomes familiar with a wider array of animals.

**Extensions:** 1. Find out as much as possible about some of the habitats in which these animals live. 2. If possible, visit some of the habitats where the animals are actually found. 3. Pick a pair of images and find out more about the life cycles of the animals shown. 4. Discuss and/or pantomime the concept of metamorphosis.

**Evaluation:** Pick two aquatic animals. Draw a picture of each animal as an adult, and another picture of each animal as it looks when it is young.

Alligator

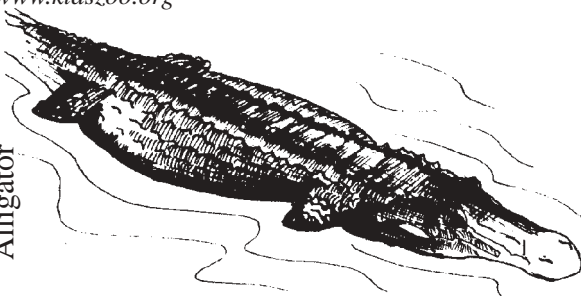

Alligator Hatchlings

Black Fly

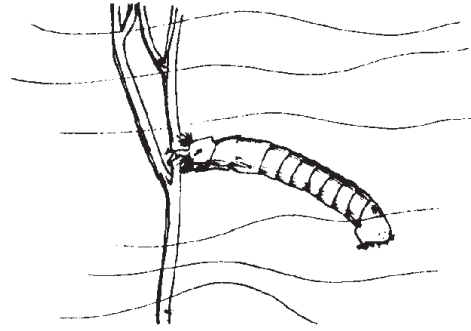
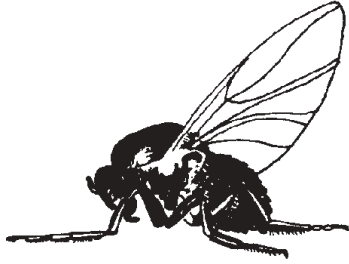

Black Fly Larva

Porpoise

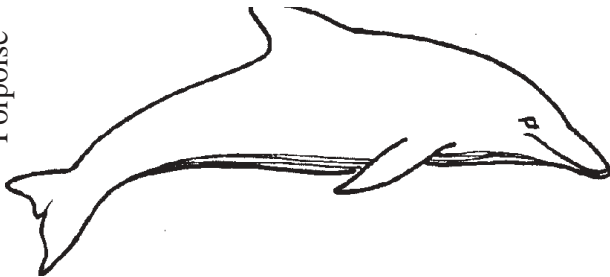

Young Porpoise

Mosquito

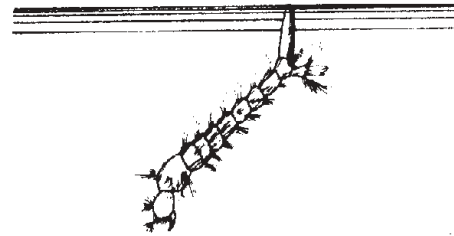
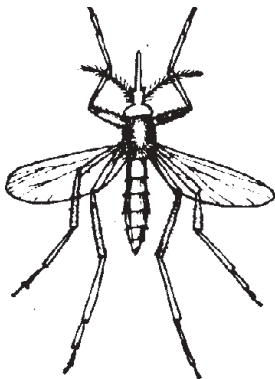

Mosquitp Larva

Adult Beaver



Young Beavers

Whirligig Beetle

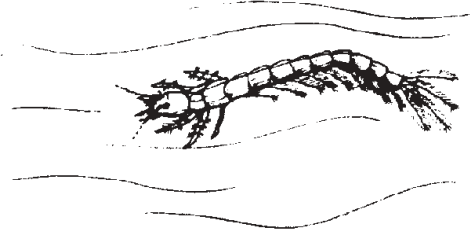

Whirligig Larva

Caddisfly

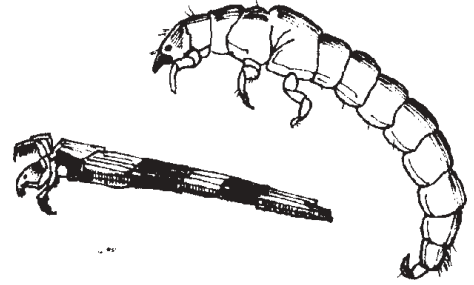

Caddisfly Larva

Dragonfly

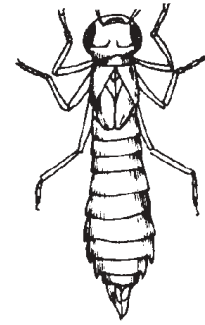
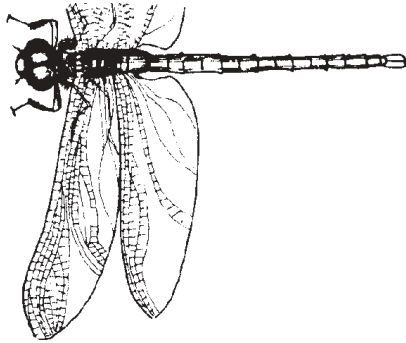

Dragonfly Nymph

Stonefly

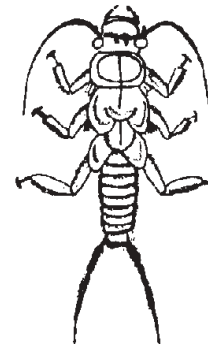
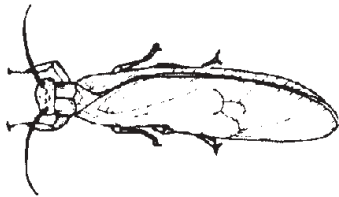

Stonefly Nymph

Osprey

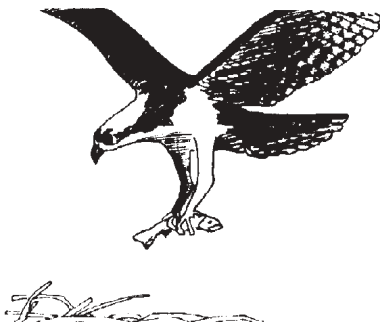

Osprey Hatchlings

Mayfly

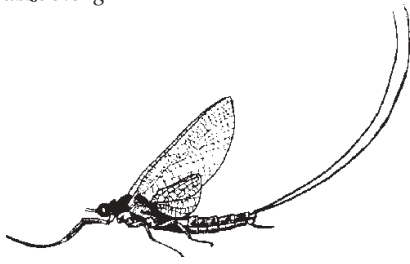

Mayfly Nymph

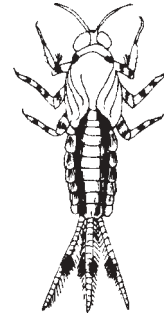

Pelican

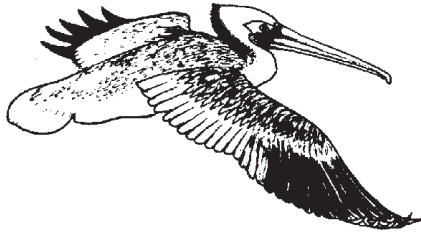

Pelican Nest and Eggs



Butterfly

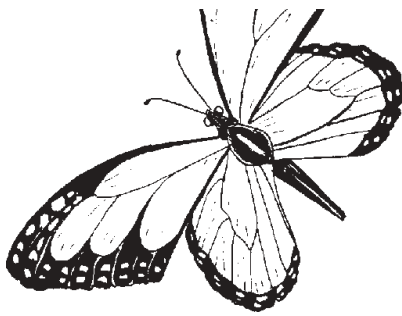

Butterfly Larva

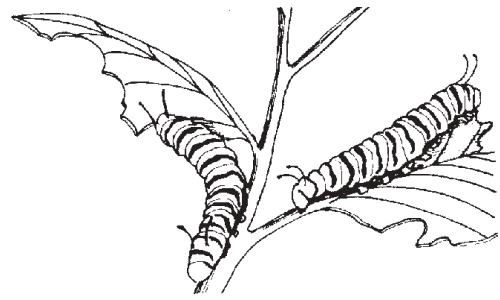

Duck

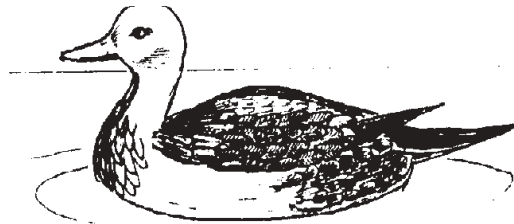

Ducklings



Frog



Tadpoles

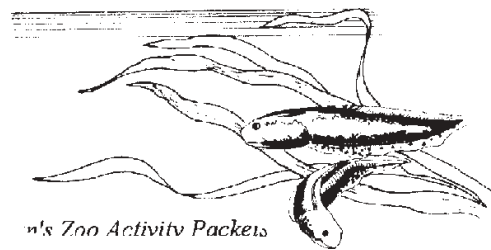

Fort Wayne Zoo Activity Packets

Sea Turtle

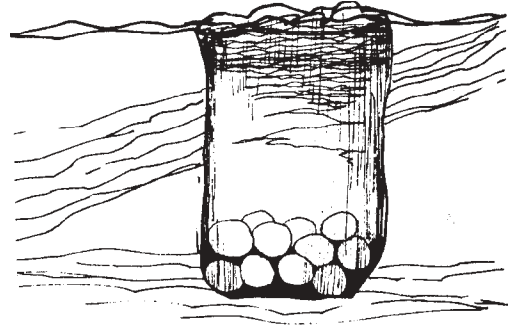
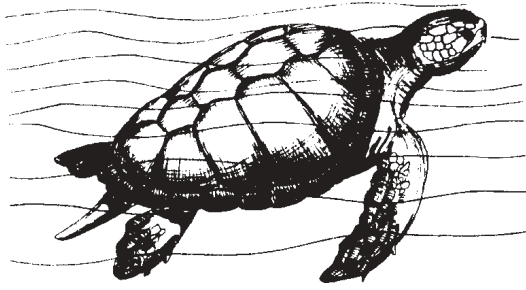

Sea Turtle Eggs

Sea Otter

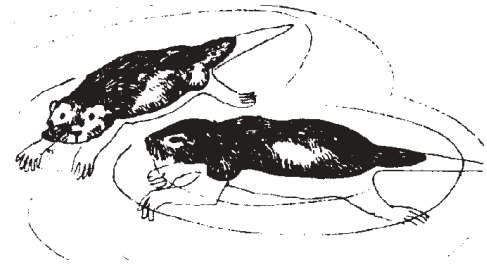

Young Sea Otters

Cranefly

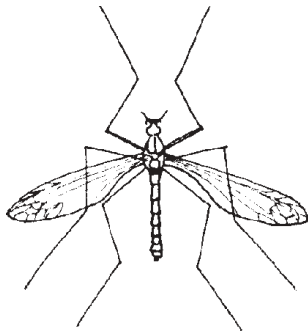

Cranefly Larva

Manatee

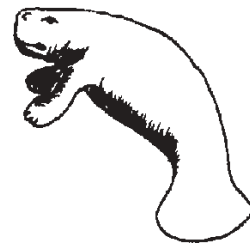
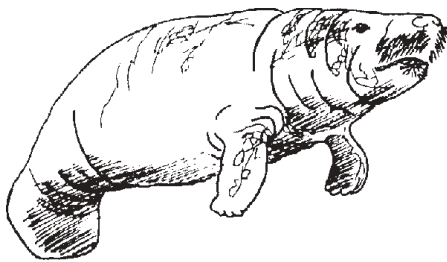

Young Manatee

Skate

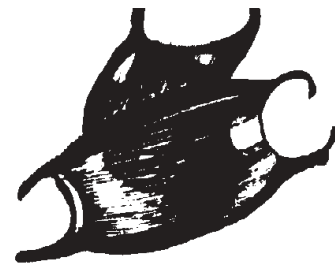
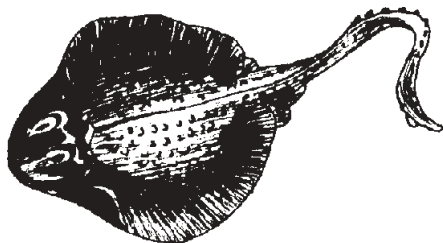

Skate Egg Cases

© 1992 Western R

Education Council.

# Go Dot-to-Dot

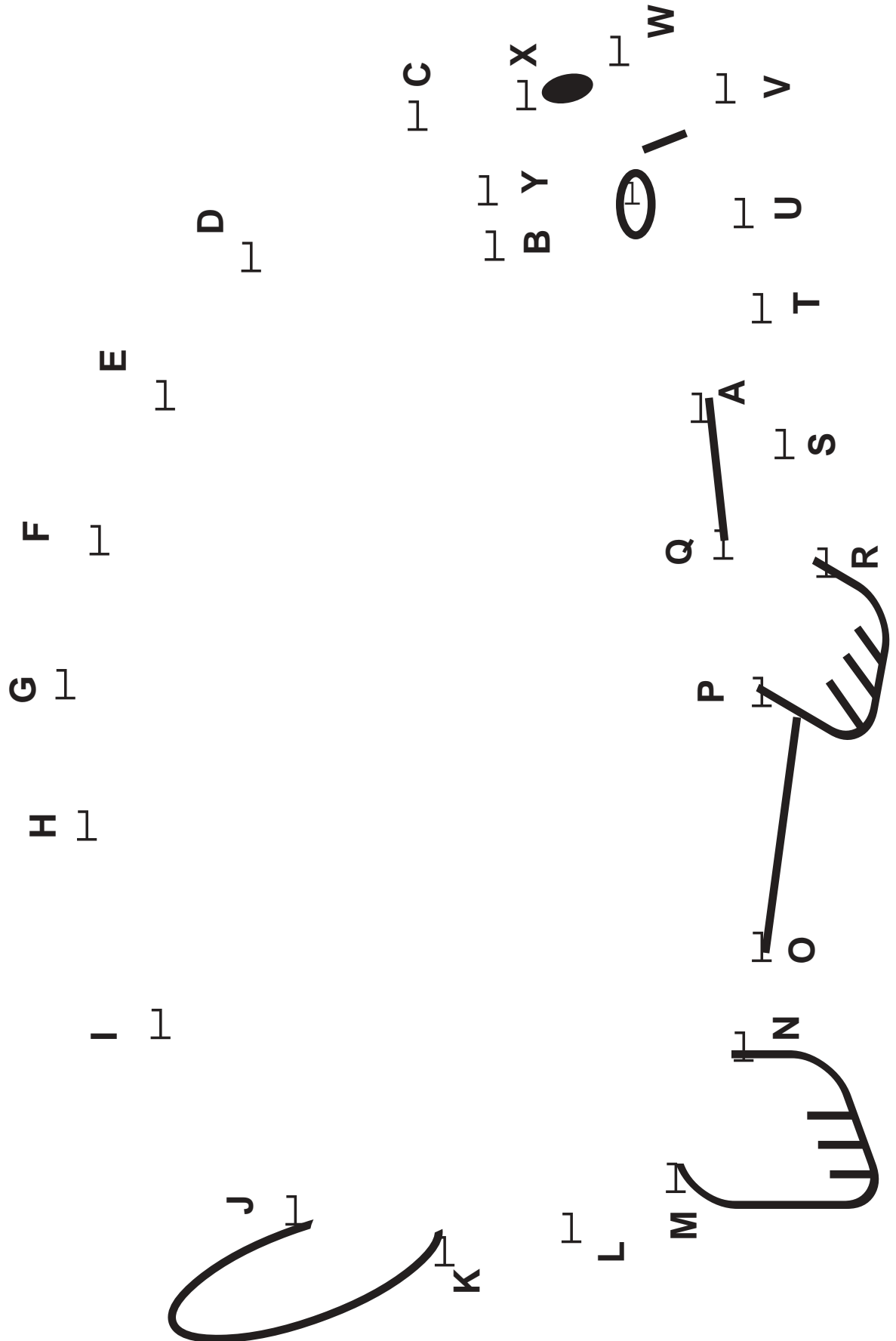

# Name Tag Patterns

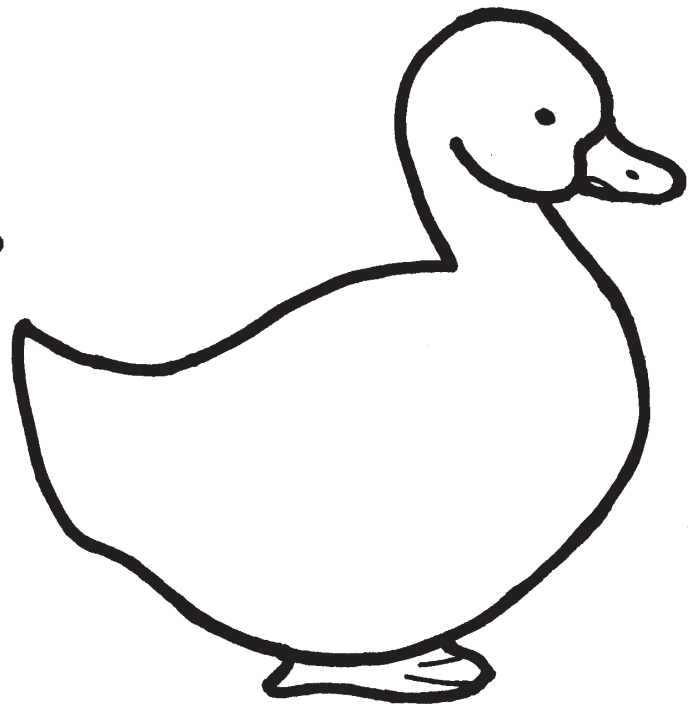
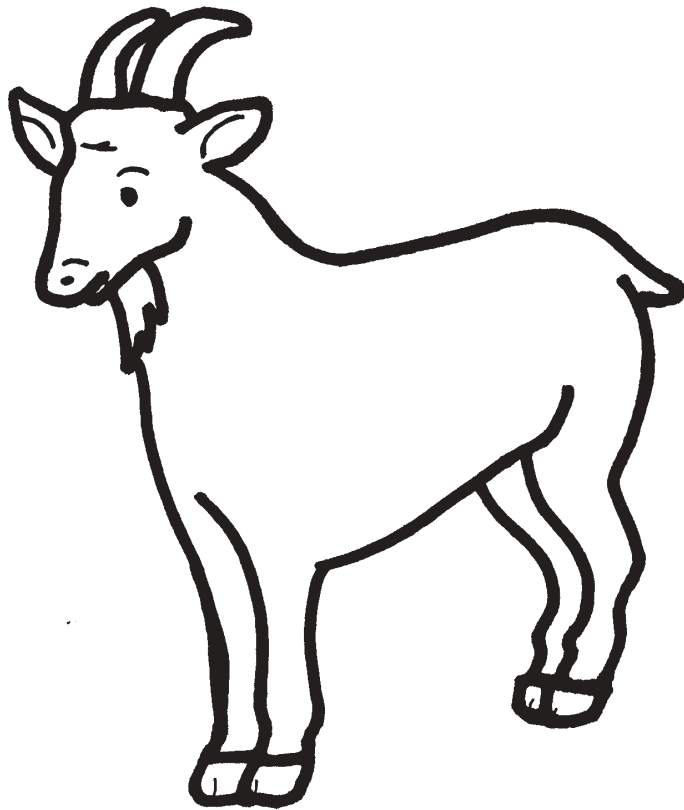



# Name Tag Patterns

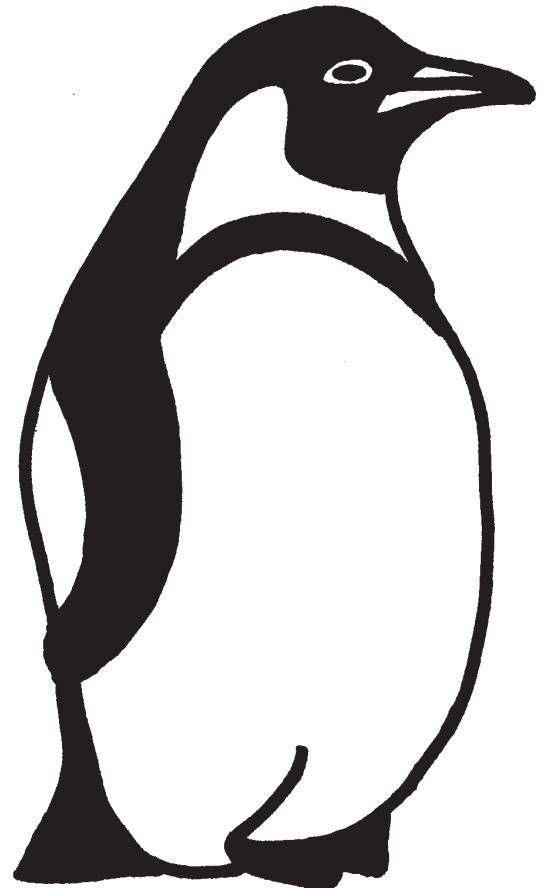
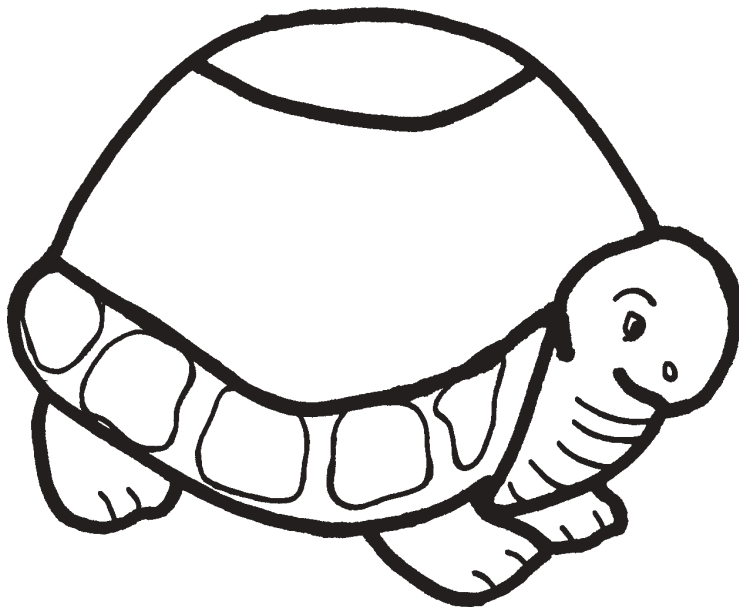

## Resources For “Bringing Up Baby” - Kindergarten

### BOOKS

Baby Bears and How They Grow. Jane Buxton. National Geographic Books for Young Explorers. 1986.

Parenting Papas: Unusual Animal Fathers. Judy Cutchins and Ginny Johnston. Morrow Junior Books. 1994

Zoo Babies. Donna K. Grosvenor. National Geographic Society. 1978.

Is Your Mama A Llama? Deborah Guarina, illustrated by Steven Kellogg. Scholastic. 1989.

Animal Babies. Bobbie Hamsa. Children’s Press. 1985.

A Time For Babies. Ron Hirschl, photographs by Thomas D. Mangelsen. Cobblehill Books. 1993.

How Animals Care For Their Babies. Roger B. Hirshland. National Geographic Books for Young Explorers. 1987.

Baby Zoo Animals. Robin James. Price Stem. 1985.

Animal Mothers. Atsushi Komori. Philomel. 1983.

What’s Hatching Out of That Egg. Patricia Lauber. Crown. 1987.

The Baby Zoo. Bruce McMillan. Scholastic Inc. 1992.

Wild Animals and Their Babies. Jan Pfloog. Western. 1987.

I Can Read About Baby Animals. Elizabeth Warren. Troll. 1985.

### AUDIO AND VIDEO TAPES

“Daddy’s Taking Us To The Zoo Tomorrow.” Peter, Paul and Mommie. Peter, Paul, and Mary. WBR Records.

Babies of the Prairie. Grunko Films Inc. 1988. This video, and the others in the series, (Babies of the Forest, Babies of the Home, Babies of the Pond, Baby Animal Fun, and Barnyard Babies) runs about 45 minutes long, and gets to a slow start. It has good footage of animal babies in the middle and toward the end, however, making parts of it well worth watching.

## General Resources for Students and Teachers

### BOOKS

- All About Alligators. Jim Arnosky. Scholastic Inc. 1994.
- Amazing Animal Disguises-Eyewitness Jr. Sandie Sowler. Alfred Knopf. 1992.
- Amazing Armored Animals-Eyewitness Jr. Sandie Sowler. Alfred Knopf. 1992.
- Amazing Cats-Eyewitness Junior. Alexandra Parsons. Alfred Knopf Co. 1990.
- Amazing Wolves, Dogs, & Foxes-Eyewitness. Mary Ling. Alfred Knopf Co. 1991.
- And Then There Was One. Margaret Facklam. Little Brown & Co. 1990.
- Animals A to Z. David McPhail. Scholastic. 1988.
- Animal Homes- Jungles. Shirley Greenisky. Newington Press. 1991.
- Animal Inventors. Thane Maynard. Franklin Watts. 1991.
- Animals of the Night. Lionel Bender. Gloucester Press. 1989.
- Animal Specialists. Nathan Aaseng. Lerner. 1987.
- Big Animals. Anne Priestley. Random House Look and Learn. 1987.
- Big Birds. Denise Casey. Cobblehill Books. 1993.
- Big Book of Amazing Animal Behavior. Tison and Taylor. Grosset and Dunlap. 1987.
- Big Cats. Bobbie Kalman. Crabtree Publishing Co. 1994.
- Big Cats - Picture Library. N.S. Barrett. Franklin Watts. 1988.
- Changing Shape - Nature's Secrets, Paul Bennett. Thomson Learning. 1994.
- Cheetah. Caroline Arnold. Morrow Junior Books. 1993
- Cheetahs - Nature's Children. Alia Smyth. Grolier. 1989.
- Conserving Rainforests. Martin Banks. Steck-Vaughn Co. 1990.
- Egg, A Photographic Story of Hatching. Robert Burton. Dorling Kindersley Inc. 1994.
- Flightless Birds - Picture Library. Norman Barrett. Franklin Watts. 1991.
- Frogs and Toads. Helen Riley. Thomson Learning. 1993.
- Gazelles - Nature's Children. Sheila Dalton. Grolier. 1990.
- Giraffe. Caroline Arnold. Morrow Junior Books. 1993.
- Giraffes - Nature's Children. Merebeth Switzer. Grolier. 1990.
- Here Is the Tropical Rain Forest. Madeleine Dunphy. Hyperion Books. 1994.
- How Speedy Is a Cheetah? Fascinating Facts About Animals. Knapp. Grosset and Dunlap. 1987.
- I Spy at the Zoo. Maureen Roffey. Four Winds. 1988.
- Journey Through A Tropical Jungle. Adrian Forsyth. Simon & Schuster. 1988.
- Kangaroo. Caroline Arnold. Morrow Junior Books. 1993.
- Kangaroos and Other Marsupials. Lionel Bender. Gloucester Press. 1988.
- Kids' World Almanac of Animals & Pets. Deborah Felder. Pharos Books. 1989.
- Llama. Caroline Arnold. Morrow Junior Books. 1993.
- Making A Nest, Nature's Secrets. Paul Bennett. Thomson Learning. 1994.
- Mammal Eyewitness Books. Steve Parker. Alfred Knopf. 1989.
- Midnight Animals. Christopher Tunney. Random House All-About Books. 1988.
- Monkey. Caroline Arnold. Morrow Junior books. 1993.
- Nature Close-Up, The Turtle. Hidetomo Oda. Raintree Publishers. 1986.
- New Zoos. Madelyn Anderson. Watts. 1987.
- Old World Monkeys - Nature's Children. Bill Ivy. Grolier. 1990.

- One-Hundred Words About Animals. Harcourt Brace. 1987.
- Orangutan. Caroline Arnold. Morrow Junior Books. 1993.
- Orangutan. Carl Green. Crestwood House. 1987.
- Orangutans. Sheila Dalton. Grolier, 1990.
- Penguin. Caroline Arnold. Morrow Junior Books. 1993.
- Rain Forest. Rene Mettler. Scholastic. 1994.
- Rain Forest. Gallimard Jeunesse. Cartwheel Books-Scholastic. 1992.
- Rain Forest. Barbara Taylor. Dorling Kindersley. 1992.
- Rain Forests - Eco Zone. Lynn Stone. Rourke Enterprises Inc. 1989.
- Rainforest Secrets. Arthur Dorros. Scholastic Inc. 1990.
- Really Radical Reptiles & Amphibians. Leslie Elliott. Sterling Publishing. 1994.
- Sea Otters, Jane Goodall's Animal World. Ruth Ashby. Atheneum. 1990.
- Secrets of the Animal World. National Geographic Society. 1986.
- Snake. Caroline Arnold. Morrow Junior Books. 1991.
- Snakes. Helen Riley. Thomson Learning. 1994.
- Strange Animals of Australia. Toni Eugene. National Geographic Society. 1991.
- Tasmanian Devil On Location. Kathy Darling. Lothrop, Lee, and Shepard Books. 1992.
- The World of Fishes. Hiroshi Takeuchi. Raintree Publishers. 1986.
- Tigers - Nature's Children. Bill Ivy. Grolier. 1990.
- Visit to the Zoo. Sylvia Tester. Children's Press. 1987.
- Weird & Wonderful Fish. Colin Milkens. Thomson Learning. 1994.
- Where's That Reptile - Hide & Seek Science. Barbara Brenner. Cartwheel Scholastic Books. 1993.
- Wonders of the Jungle. National Wildlife Federation. 1987.
- Zebra. Caroline Arnold. Morrow Junior Books. 1993.
- Zoo. Gail Gibbons. Crowell. 1987.
- Zoos. Miriam Moss. Bookwright Topics. 1987.

## **MAGAZINES**

National Geographic World  
National Geographic Society  
P.O. Box 2330  
Washington, D.C. 20013-23

### Wildlife Conservation

Available as part of Fort Wayne Zoological Society membership or from Bronx Zoo/Wildlife Conservation Park  
Bronx, NY 10460

### Science and Children

National Science Teachers Assoc.  
1742 Connecticut Ave., N.W.  
Washington, D.C. 20009-1171

### Ranger Rick

National Wildlife Federation  
8925 Leesburg Pike  
Vienna, VA 22184-0001

### Your Big Backyard

National Wildlife Federation  
P.O. Box 777  
Mt. Morris, IL 61054-0777

### Owl Magazine

25 Boxwood Lane  
Buffalo NY 14227

### Dolphin Log

The Cousteau Society  
870 Greenbrier Circle, Suite 402  
Chesapeake, VA 23320

### 3-2-1 Contact

Children's Television Workshop  
P.O. Box 53051  
Boulder CO 80322-3051

### Scienceland

Scienceland Inc.  
501 Fifth Ave., Ste. 2108  
New York, NY 10017-6165

### Project Learning Tree

American Forest Council  
1250 Connecticut Ave., N.W.  
Washington, D.C. 20036

### Project WILD/Aquatic Project WILD

Western Regional Environmental  
Education Council  
Salina Star Route  
Boulder, CO 80302

Ranger Rick's Naturescope  
National Wildlife Federation  
1400 16th Street, N.W.  
Washington, D.C. 20036-2266

### 3-2-1-Contact

E=Mc Square  
P.O. Box 51177  
Boulder, CO 80322-1177

### ZOOBOOKS.

P.O. Box 85384  
San Diego, CA 92103.

## **VIDEOS**

3-2-1 Classroom Contact: Australian Mammals - Life Down Under. 3-2-1 Contact Classroom Video Series. 1991. 15 min.

3-2-1 Classroom Contact: Social Behavior -- Living Groups. 3-2-1 Contact Classroom Video Series. 1991. 15 min.

African Animals -- Nature Series, Educational Favorites. Trans Atlantic Video. 1988. 30 min.  
African Wildlife. National Geographic Society. 1990. 60 min.

Animals of the Night, Children's Series Animal in Action. Kodak Video Programs. 1988. 30 min.  
Big Cats of the World. Aims. 1994. 19 min.

Cool Creatures: Reptiles. Rainbow. 1994. 22 min.

Dive to the Coral Reefs. Reading Rainbow. 1990. 30 min.

Food Chains -- Eat and Be Eaten. 3-2-1 Contact Classroom Video Series. 1991. 15 min.

Giraffes and How They Live. Aims. 1994. 19 min.

How We Classify Animals. Aims. 1990. 14 min.

Lions of the African Night. National Geographic Society. 1986. 60 min.

Mountain Animals, Children's Series Animals in Action. Kodak Video Programs. 1988. 30 min.

Penguins, Nature Series, Education Favorites. Trans Atlantic Video. 1988. 30 min.

Rain Forest: More Complicated Than You Thought. Aims. 1993. 15 min.

Reptiles, Nature Series, Educational Favorites. Trans Atlantic Video. 1986. 30 min.

**VIDEOS**, continued

Shooting Africa, A Photo Safari Video. Questar Travel Network Productions. 1988. 60 min.

Snakes and How They Live. Aims. 1988. 12 min.

Stellaluna. Reading Rainbow. 1990. 30 min.

The Turtle Family, Children's Series Animals in Action. Kodak Video Programs. 1988. 30 min.

Tree Living Animals, Children's Series Animals in Action. Kodak Video Programs. 1988. 30 min.

You Can't Grow Home Again. 3-2-1 Contact Classroom Video Series. 1991. 60 min.

Zoo, Zoo, Zoo: Animal Groups. Agency for Instructional Technology (AIT). 1993. 15 min.

**SOFTWARE**

<b>TITLE</b>	<b>GRADE</b>	<b>TYPE</b>	<b>PUBLISHER</b>
ABC's Wide World of Animals	4 - 12	MAC/CD/Windows	Creative Wonders
Destination Rain Forest	K - 6	MAC/CD	Edmark
Discovering Endangered Wildlife	4 - 12	CD/Windows	Queue
ECO Adventures in the Rainforest	3 - 12	MAC/Windows	Chariot Software
How Animals Move	4 - 12	MAC/CD/Windows	Discovery Channel
How We Classify Animals	3 - 6	MAC/CD/Windows	ClearVue
Introduction to Vertebrates	3 - 6	MAC/CD/Windows	ClearVue
Learning All About Animals	3 - 6	MAC/CD/DOS	Queue
Mammals of Africa	4 - 12	MAC/CD/Windows	RE Media (Sunburst)
Ocean Explorers and Zoo Explorers	K - 5	CD	Compton's
Ocean Life -- Great Barrier Reef	4 - 12	MAC/CD	Sumeria
Odell Down Under -- Great Barrier Reef	3 - 12	MAC/Windows	MECC
Rainforest Bundle	4-8	MAC/Windows	Sunburst
Rainforest Explorer	4 & up	MAC/CD/Windows	Orange Cherry
San Diego Zoo Presents The Animals 2.0	2 - 12	MAC/CD	Mindscape
Scavenger Hunt Adventure Series: Africa	3 - 12	MAC/CD/Windows	Swe
The Great Ocean Rescue	5 - 8	MAC/Windows	Tom Snyder Prod.
The World of Reptiles	3 - 6	MAC/CD/Windows	ClearVue
Virtual Reality Bird	4 - 12	CD/Windows	DK Multimedia
Virtual Reality Cat	4 - 12	CD/Windows	DK Multimedia
Zoo Keeper	3 - 8	MAC/Windows	Davidson
Zootopia	3 - 12	MAC/CD/Windows	Lawrence
Zurk's Rainforest Lab	K - 3	MAC/CD/Windows	Soliel Software

# Evaluation Form Zoo Activity Packet

Dear Teacher:

Please take a few minutes to fill out and return this evaluation form. Your input will help us improve our teacher resource materials in the future.

Return in the envelope provided or mail to Education Department, Fort Wayne Children's Zoo, 3411 Sherman Blvd., Fort Wayne, IN 46808. Thank you for your time and effort!

SCHOOL or GROUP NAME: \_\_\_\_\_

GRADE LEVEL: \_\_\_\_\_ DATE OF VISIT: \_\_\_\_\_

1. Were the materials and activities appropriate for your grade level? \_\_\_\_\_

\_\_\_\_\_

2. Which work sheets did you use? \_\_\_\_\_

\_\_\_\_\_

3. Which activities did you try? \_\_\_\_\_

\_\_\_\_\_

4. Which of these were enjoyed most by your students? \_\_\_\_\_

\_\_\_\_\_

5. Did you create or modify any activities to supplement this packet? If so, we would appreciate receiving a copy to include in future packets or to distribute to teachers on request.

6. What other materials would you like to see included in the packet? \_\_\_\_\_

\_\_\_\_\_

7. Additional comments: \_\_\_\_\_

\_\_\_\_\_

\_\_\_\_\_